

Steel ball valves, reduced bore

welding/welding, EN (DIN), DN 10-250

Body:	DN 10–500 Steel, P235GH (1.0345) DN 600–800 Steel, P355 NL1 (1.0566)/ GP240GH (1.0619)
Ball:	DN 10–600 Stainless steel, X5CrNi18-10 (1.4301) DN 700–800 Steel + stainless plating, ASTM A350 LF2+Ni
Stem:	Stainless steel, X8CrNiS18-9 (1.4305)
Stem seals:	FPM
Ball seals:	PTFE+C
Operation:	With zinc-plated steel handle We recommend manual gear operation for sizes DN 200 and larger

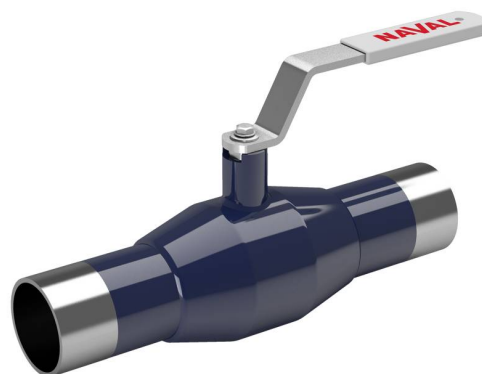

Operating conditions

-30°C - +200°C

Below 0 °C contact manufacturer

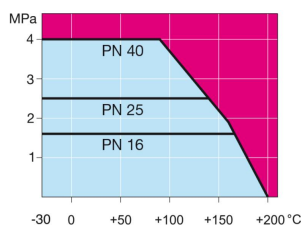

Not for steam

DN 10 - 150

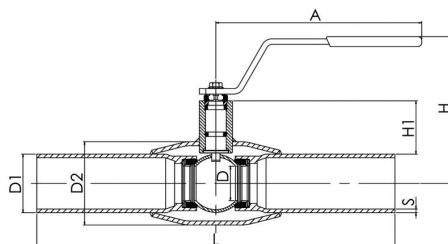

DN 200 - 250

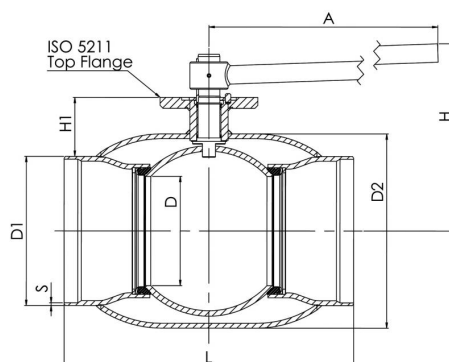

Product no. Naval	DN	PN	A	D	D1	D2	H	H1	L	S	kg
284402	10	40	145	10	17.2	33.7	98	22	230	2	0.6
284403	15	40	145	10	21.3	33.7	98	22	230	2	0.6
284405	20	40	145	15	26.9	42.4	103	23	230	2.3	0.8
284406	25	40	145	20	33.7	48.3	118	34	230	2.6	1
284407	32	40	145	25	42.4	60.3	121	33	260	2.6	1.4
284408	40	40	188	32	48.3	70	120	43	260	2.6	1.8
284409	50	40	188	40	60.3	88.9	127	44	300	2.9	2.6
284410	65	25	277.5	50	76.1	101.6	159	62	300	2.9	4
284411	80	25	277.5	65	88.9	121	171	68	300	3.2	5.3
284412	100	25	278.5	80	114.3	146	218	101	325	3.6	8.3
284413	125	25	400	100	139.7	177.8	252	101	325	4	13.4
284414	150	25	600	125	168.3	219.1	272	107	350	4.5	18
284416	200	25	870	150	219.1	273	280	92	400	4.5	39
284417	250	25	1200	200	273	355.6	350	108	530	5	74